



ALASKA RAILROAD CORPORATION
327 W. Ship Creek Ave.
Anchorage, AK 99501
Phone 907-502-0007
HumphreyC@akrr.com

August 16, 2023

Addendum Number 3

ITB 23-45-210858

SECTION TRUCK SERVICE BODY

This addendum is issued to provide information as follows:

Bid Closing Date: 08.22.2023 @ 3:00 PM Alaska time

Section B: Scope of Work has been replaced in its entirety.

If you have already submitted a bid, you may resubmit your cost schedule and the attached Service Bid Form. If you have already submitted a bid and have no necessary changes, please submit the Service Bid Form acknowledging receipt of the addendums.

Please acknowledge receipt of this and all addendums via email. **All other dates, terms and conditions remain unchanged.**

Please direct all responses and/or questions concerning this solicitation to Candice Humphrey, via email HumphreyC@akrr.com.

Respectfully,

Candice Humphrey
Contract Administration Specialist

SECTION B SCOPE OF WORK

Section truck aluminum service bodies for our 2022 Ford F-350 60" CA SRW
Total Quantity: Four (4)

- 108" long x 40" high x 78" wide
- Headache rack for work lights & strobe light
- 40" compartment height, 18" compartment depth, 48.5" load space width, 23" top of body to top of floor, 17" horizontal compartment height
- 2000lb utility crane mounted on top of curb side tool tray right rear corner 12v power with wired remote and quick connect plug in
- Master locking system on body
- Spot light
- Hose reel 50ft 1/2" arctic grade: Hose reel is for Hydraulic Tool circuit:
Chassis engine driven hydraulic tool circuit w/ valves & self-winding (25' length - Stanley recommendation for hose diameter & manufacturer) hose reel mounted on drivers side rear on top of tool boxes. Hydraulic specs: 10gpm@2,000 psi & 5gpm at 2,000 psi continues with a twin line hose
- Aluminum tool holders
- Custom tool holder rear bumper

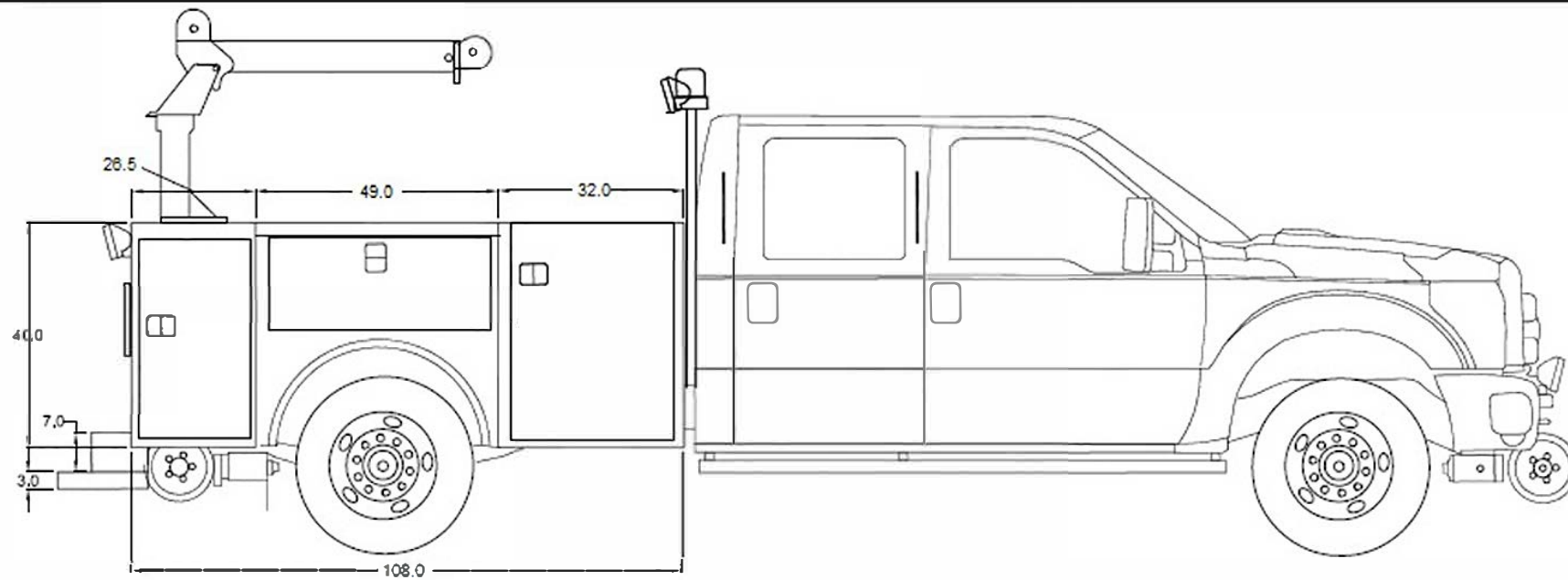
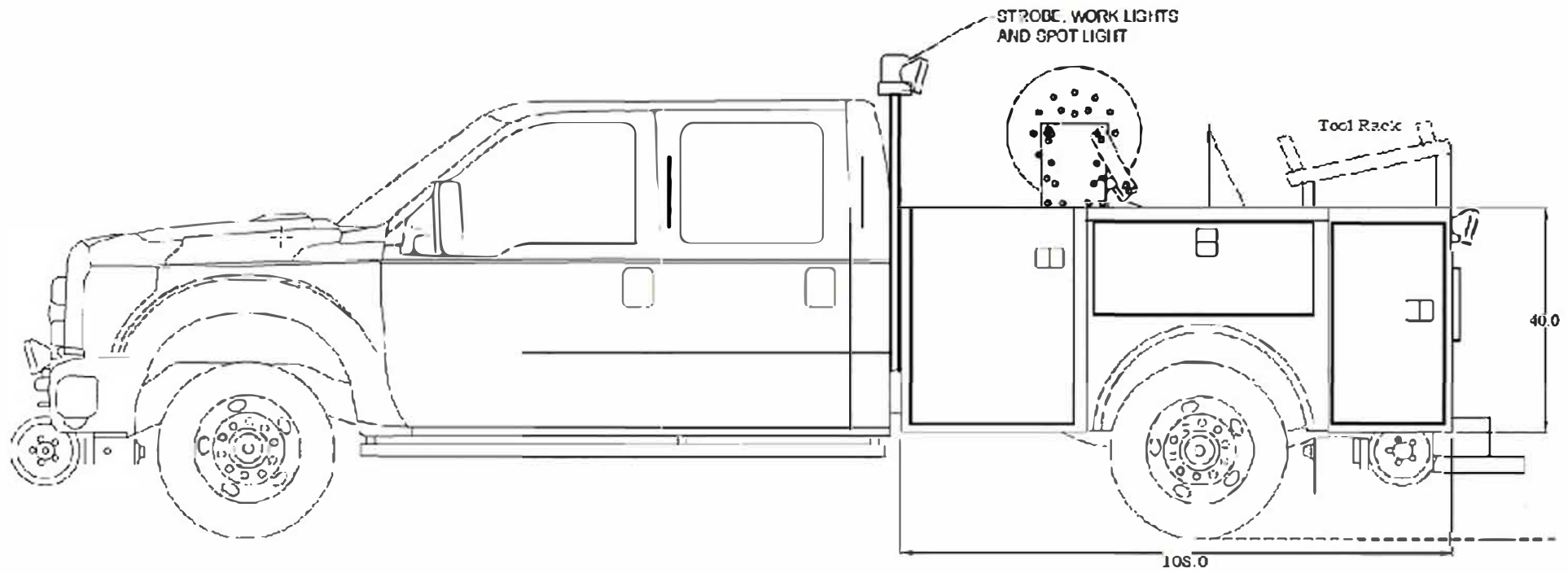

NOT TO SCALE

Revised 08.15.2023

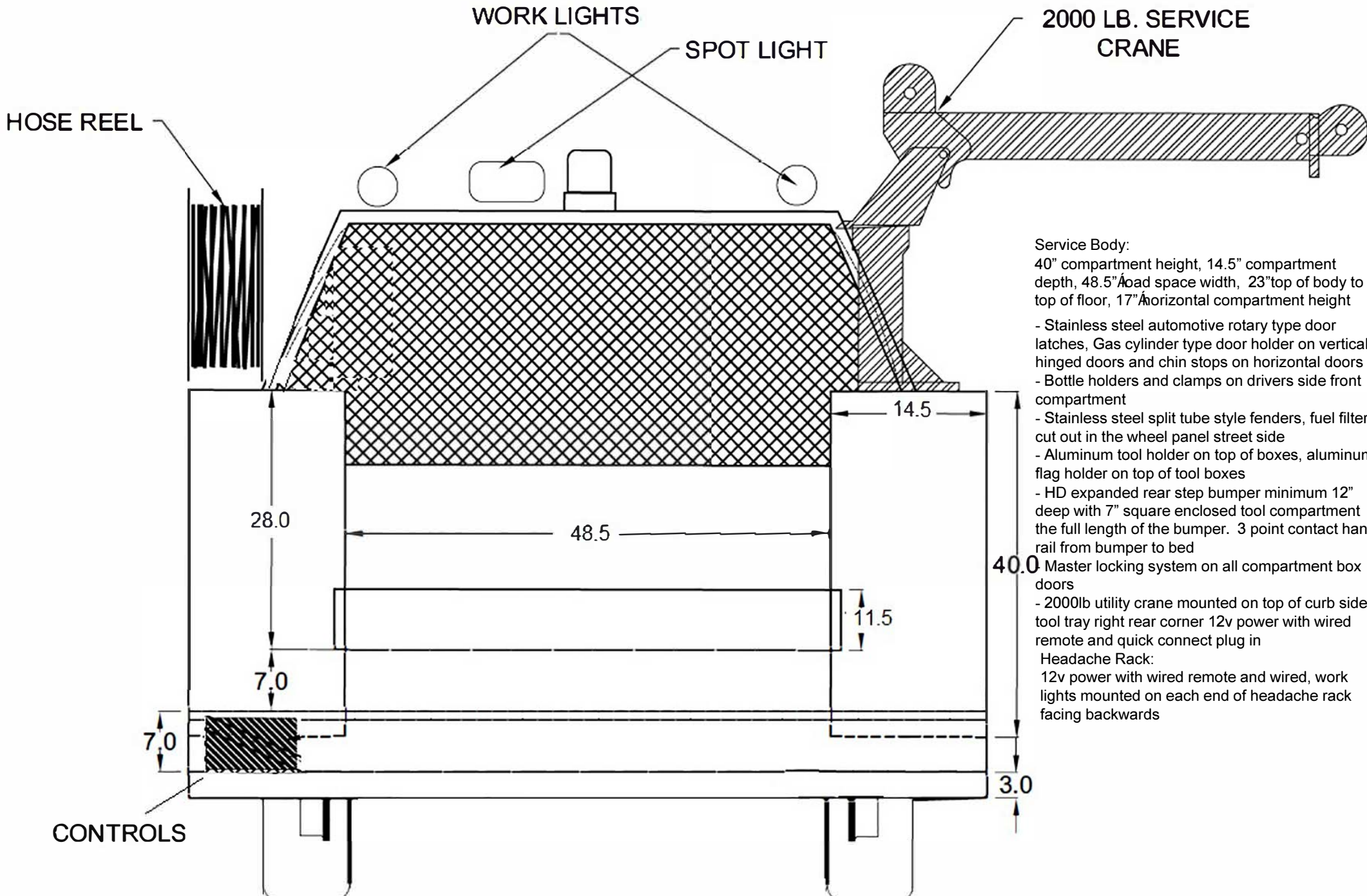

- Service Body:
- 40" compartment height, 14.5" compartment depth, 48.5" load space width, 23" top of body to top of floor, 17" horizontal compartment height
 - Stainless steel automotive rotary type door latches, Gas cylinder type door holder on vertically hinged doors and chin stops on horizontal doors
 - Bottle holders and clamps on drivers side front compartment
 - Stainless steel split tube style fenders, fuel filter cut out in the wheel panel street side
 - Aluminum tool holder on top of boxes, aluminum flag holder on top of tool boxes
 - HD expanded rear step bumper minimum 12" deep with 7" square enclosed tool compartment the full length of the bumper. 3 point contact hand rail from bumper to bed
 - Master locking system on all compartment box doors
 - 2000lb utility crane mounted on top of curb side tool tray right rear corner 12v power with wired remote and quick connect plug in
- Headache Rack:
- 12v power with wired remote and wired, work lights mounted on each end of headache rack facing backwards

**ALASKA RAILROAD CORPORATION
SERVICE BID FORM of**

NAME _____
ADDRESS _____

To the CONTRACTING OFFICER, ALASKA RAILROAD CORPORATION:

In compliance with your Invitation for Bids No. _____, dated _____, the Undersigned proposes to furnish and deliver all the services and perform all the work required in said Invitation according to the specifications and requirements contained therein and for the amount and prices named herein as indicated on the Cost Schedule, which is made a part of this Bid.

The Undersigned hereby agrees to execute said contract and bonds, if any, within **Ten (10) Calendar Days**, or such further time as may be allowed in writing by the Contracting Officer, after receiving notification of the acceptance of this Bid, and it is hereby mutually understood and agreed that in case the Undersigned does not, the accompanying bid guarantee, if any, shall be forfeited to the Alaska Railroad Corporation as liquidated damages, and said Contracting Officer may proceed to award the contract to others.

The Undersigned agrees to commence performance within **Ten (10) Calendar Days** after the effective date of the Notice to Proceed and to complete performance by _____, unless extended in writing by the Contracting Officer.

The Undersigned acknowledges receipt of the following addenda to the requirements and/or specifications for this Invitation for Bids (give number and date of each).

Addenda Number	Date Issued	Addenda Number	Date Issued	Addenda Number	Date Issued
_____	_____	_____	_____	_____	_____
_____	_____	_____	_____	_____	_____

NON-COLLUSION AFFIDAVIT

The Undersigned declares, under penalty of perjury under the laws of the United States, that neither he/she nor the firm, association, or corporation of which he/she is a member, has, either directly or indirectly, entered into any agreement, participated in any collusion, or otherwise taken any action in restraint of free competitive bidding in connection with this Bid.

The Undersigned has read the foregoing proposal and hereby agrees to the conditions stated therein by affixing his/her signature below:

Name and Title of Person Signing	Signature
Telephone Number	Facsimile Number
395-0129 (12/99)	